









Read this instruction carefully. See hardware and furniture part list for guidance. Be sure all parts are complete, before you assemble. Place all wooden furniture parts on a clean and flat soft surface to prevent from being scratched. Follow the figure to start assembling.

CAUTIONS : 1. Do not FULLY - TIGHTEN the nut or nut bolt until all nut or bolt is ready assembled.
 2. Do not OVER - TIGHTEN the nut or bolt to avoid causing damages to the thread.
 3. Keep all hardware parts out of reach of children.

NOTE : THE LIST AND QUANTITY SHOWN ARE FOR 1 UNIT ASSEMBLY.
 Tool needed : Screwdriver & Rubber Mallet (not provider).

PART LIST		
ITEM	DESCRIPTION	QTY
A	ARM (LEFT)	1 PC
B	ARM (RIGHT)	1 PC
C	SIDE RAIL (BACK)	1 PC
D	SIDE RAIL (FRONT)	1 PC
E	TRUNDLE (FRONT RAIL)	1 PC
F	BED SLAT	26 PCS
G	CENTER RAIL	1 PC
H	CENTER SUPPORT	2 PCS
I	BACK REST	1 PC
J	ARM SUPPORT WOOD	2 PCS

HARDWARE LIST		
ITEM	DESCRIPTION	QTY
1	WOOD SCREW M3.5 x 16mm 	8 PCS
2	BED SLAT SIDE FITTER 	26 PCS
3	BED SLAT CENTER FITTER 	13 PCS
4	JCBC BOLT M6 x 50mm 	6 PCS
5	WOOD DOWEL M8 x 30mm 	2 PCS
6	M6 FLAT WASHER 	4 PCS
7	M4 ALLEN KEY (BALL SHAPE) 	1 PC
8	M5 ALLEN KEY (BALL SHAPE) 	1 PC

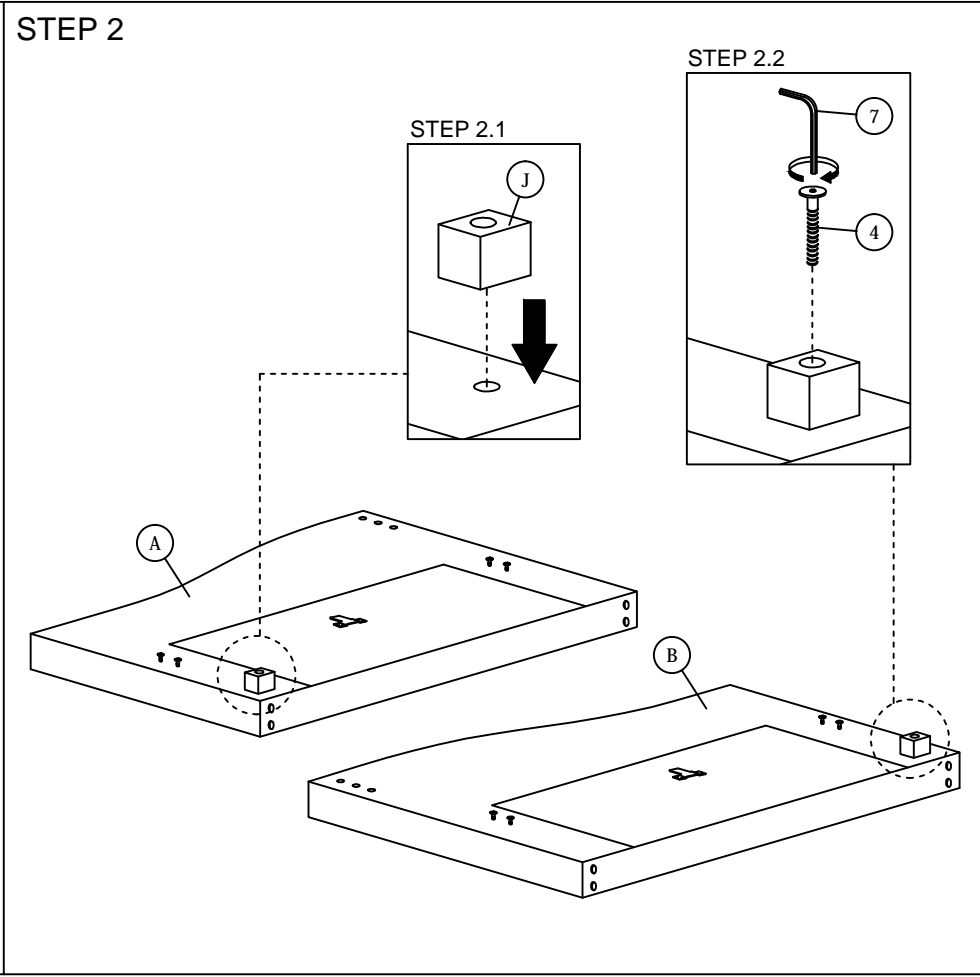
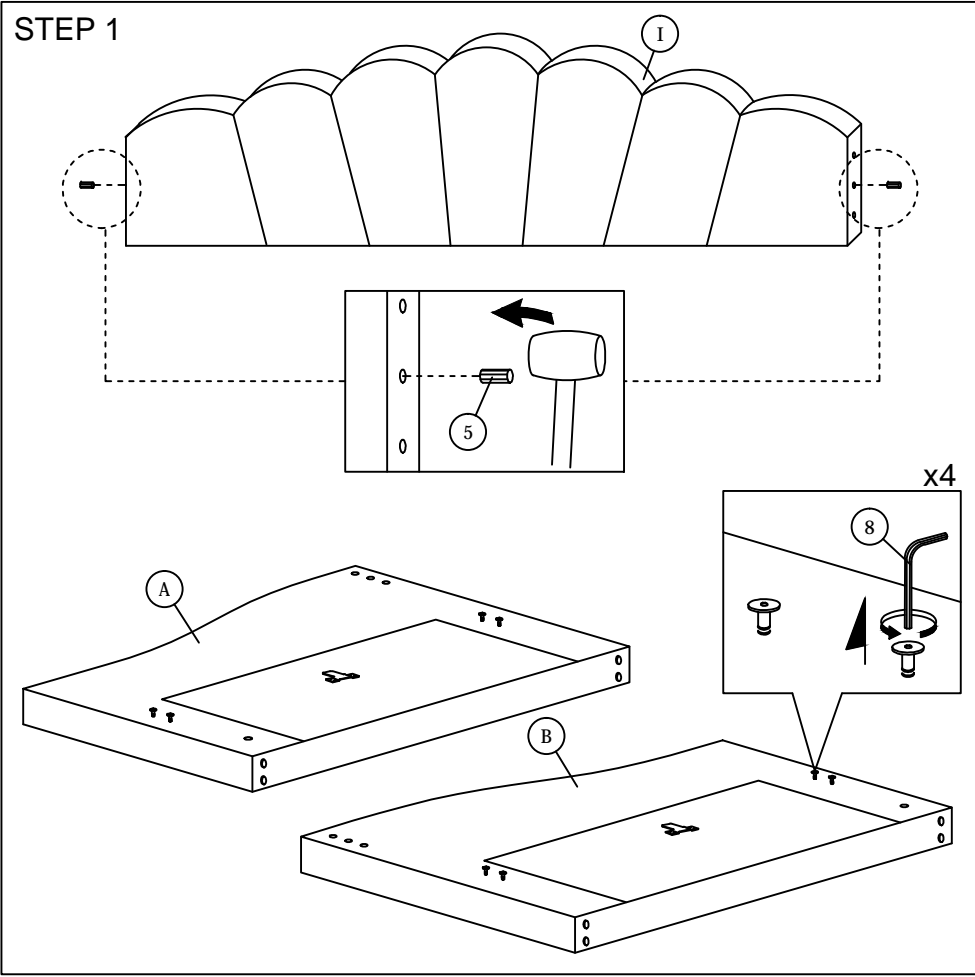

ASSEMBLY INSTRUCTIONS

STEP 3

Don't screw tied

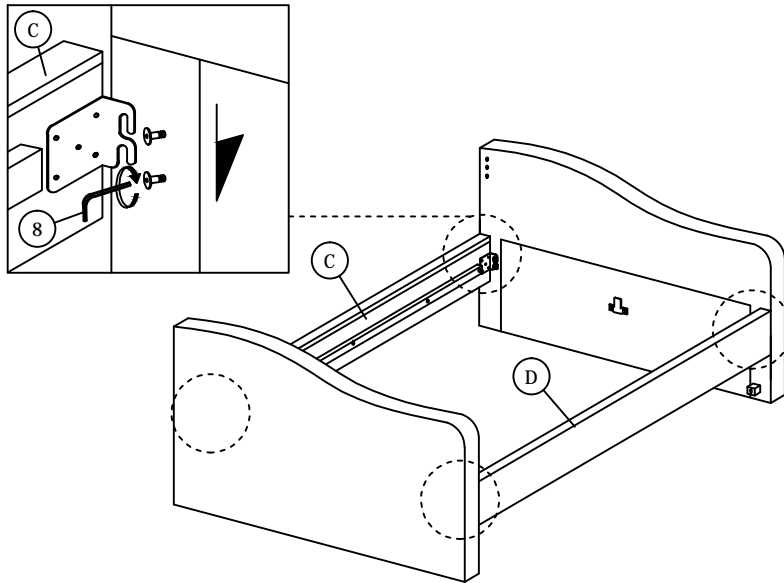

STEP 4

****Finish step 4,
Please screw tied the step 3 bolt.**

STEP 4.1 x2

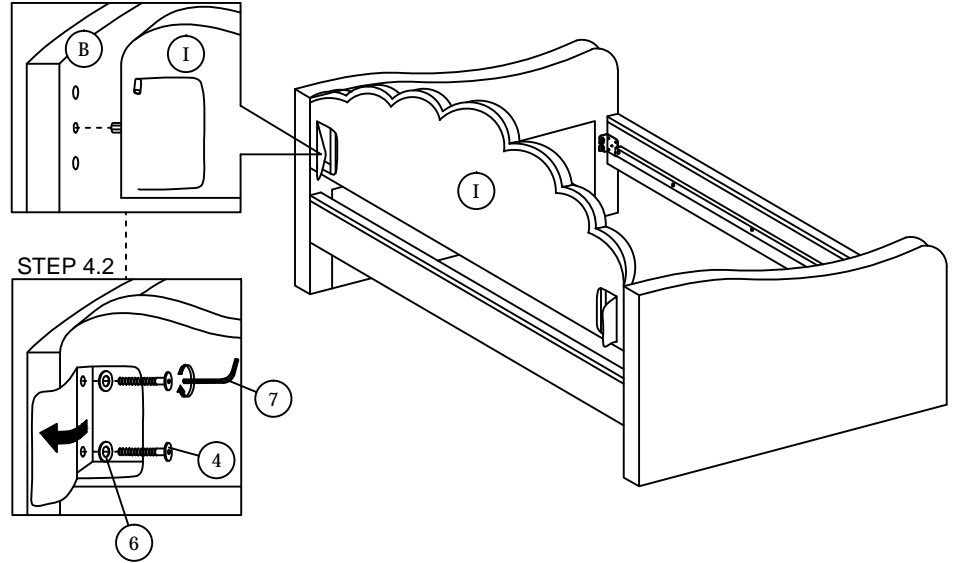

STEP 4.2

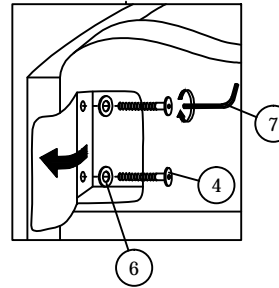

STEP 5

STEP 5.1

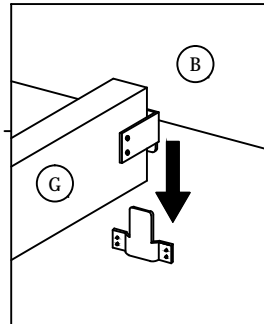

STEP 5.2

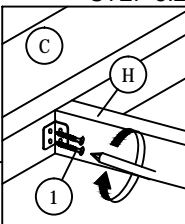

STEP 6

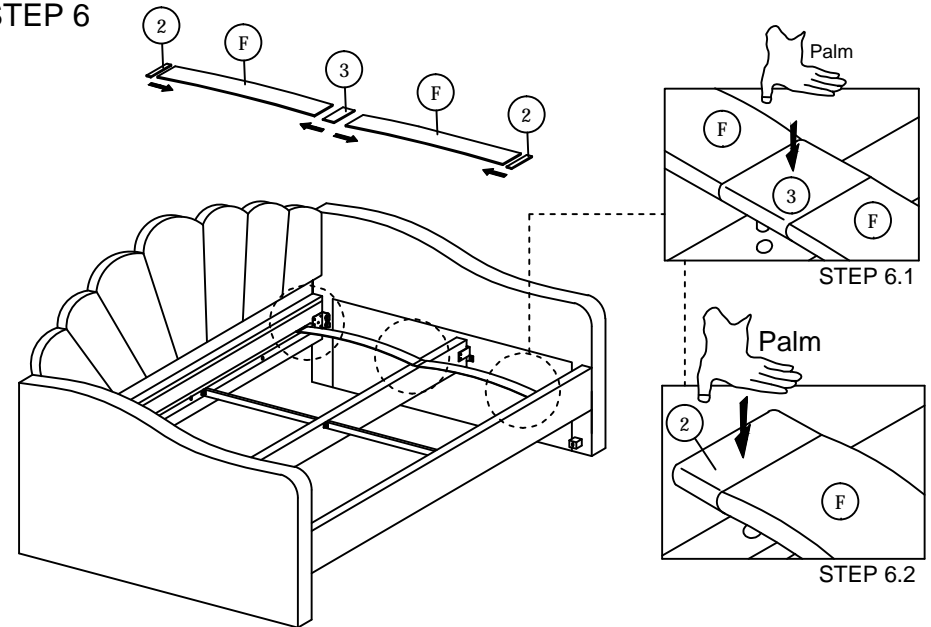

ASSEMBLY INSTRUCTIONS

STEP 7

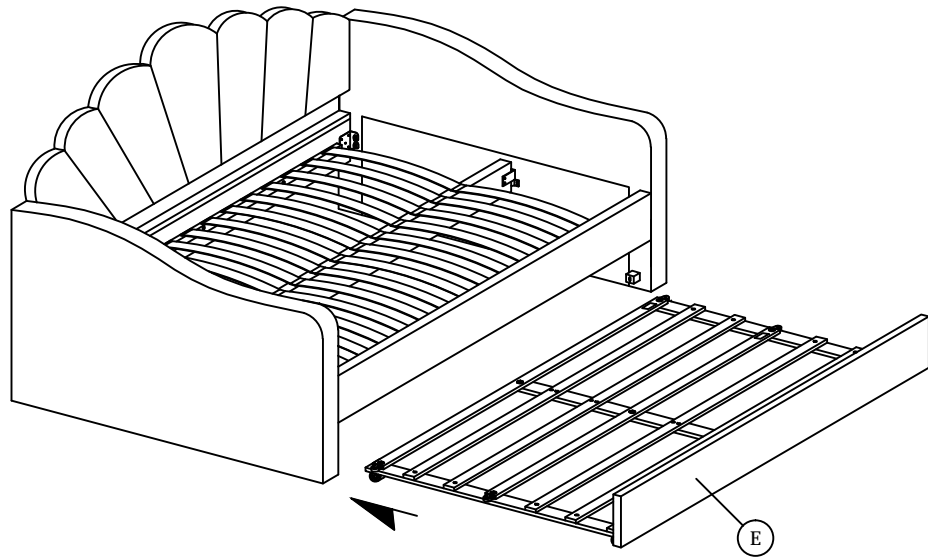

STEP 8

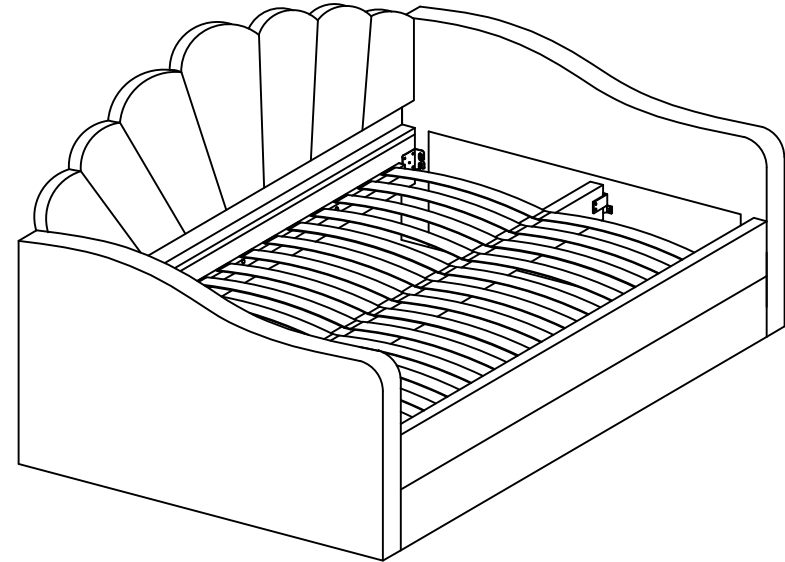
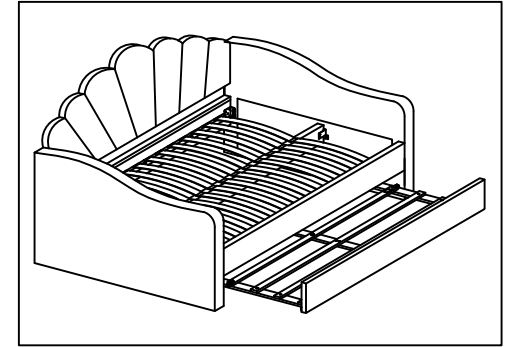

Read this instruction carefully. See hardware and furniture part list for guidance. Be sure all parts are complete, before you assemble. Place all wooden furniture parts on a clean and flat soft surface to prevent from being scratched. Follow the figure to start assembling.

- CAUTIONS :**
1. Do not FULLY - TIGHTEN the nut or nut bolt until all nut or bolt is ready assembled.
 2. Do not OVER - TIGHTEN the nut or bolt to avoid causing damages to the thread.
 3. Keep all hardware parts out of reach of children.

NOTE : THE LIST AND QUANTITY SHOWN ARE FOR 1 UNIT ASSEMBLY.

Tool needed : Screwdriver (not provider).

PART LIST		
ITEM	DESCRIPTION	QTY
A	SLAT	1 PC
B	SLAT WITH TRUNDLE	2 PCS
C	SLAT	4 PCS
D	TRUNDLE (FRONT RAIL)	1 PC
E	TRUNDLE SUPPORT WOOD (FRONT RAIL)	3 PCS
F	TRUNDLE SUPPORT (FRONT RAIL)	2 PCS

HARDWARE LIST		
ITEM	DESCRIPTION	QTY
1	JCBC BOLT M6 x 35mm	13 PCS
2	JCBC BOLT M6 x 60mm	4 PCS
3	M6 SPRING WASHER	4 PCS
4	M6 FLAT WASHER	4 PCS
5	WOOD SCREW M4 x 38mm	16 PCS
6	M4 ALLEN KEY (BALL SHAPE)	1 PC

